

# R&S® ZVAX-TRM Extension Unit Specifications



# CONTENTS

<b>Definitions .....</b>	<b>3</b>
<b>Specifications.....</b>	<b>4</b>
Options.....	5
R&S®ZVAX-TRM topology.....	7
Dimensions (in mm).....	8
Connectors.....	9
<i>Front panel connectors.....</i>	<i>10</i>
<i>Rear panel connectors.....</i>	<i>11</i>
General data.....	12
<b>Ordering information .....</b>	<b>13</b>

# Definitions

## General

Product data applies under the following conditions:

- Three hours storage at ambient temperature followed by 30 minutes warm-up operation
- Specified environmental conditions met
- Recommended calibration interval adhered to
- All internal automatic adjustments performed, if applicable

## Specifications with limits

Represent warranted product performance by means of a range of values for the specified parameter. These specifications are marked with limiting symbols such as  $<$ ,  $\leq$ ,  $>$ ,  $\geq$ ,  $\pm$ , or descriptions such as maximum, limit of, minimum. Compliance is ensured by testing or is derived from the design. Test limits are narrowed by guard bands to take into account measurement uncertainties, drift and aging, if applicable.

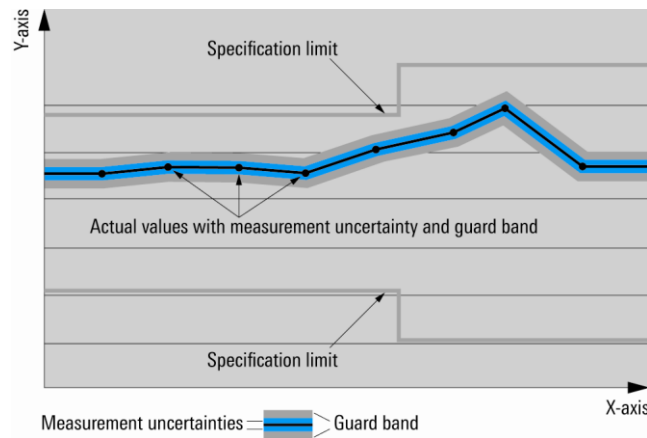

## Specifications without limits

Represent warranted product performance for the specified parameter. These specifications are not specially marked and represent values with no or negligible deviations from the given value (e.g. dimensions or resolution of a setting parameter). Compliance is ensured by design.

## Typical data (typ.)

Characterizes product performance by means of representative information for the given parameter. When marked with  $<$ ,  $>$  or as a range, it represents the performance met by approximately 80 % of the instruments at production time. Otherwise, it represents the mean value.

## Nominal values (nom.)

Characterize product performance by means of a representative value for the given parameter (e.g. nominal impedance). In contrast to typical data, a statistical evaluation does not take place and the parameter is not tested during production.

## Measured values (meas.)

Characterize expected product performance by means of measurement results gained from individual samples.

## Uncertainties

Represent limits of measurement uncertainty for a given measurand. Uncertainty is defined with a coverage factor of 2 and has been calculated in line with the rules of the Guide to the Expression of Uncertainty in Measurement (GUM), taking into account environmental conditions, aging, wear and tear.

Device settings and GUI parameters are indicated as follows: "parameter: value".

Typical data as well as nominal and measured values are not warranted by Rohde & Schwarz.

## Specifications

Frequency range	unless differing for particular options	
	R&S®ZVAX-TRM24	10 MHz to 24 GHz
	R&S®ZVAX-TRM40	10 MHz to 40 GHz
	R&S®ZVAX-TRM50	10 MHz to 50 GHz
	R&S®ZVAX-TRM67	10 MHz to 67 GHz
Dynamic range from port 1 to port 2, maximum available output power, 10-Hz-IF measurement bandwidth		
R&S®ZVAX-TRM with all options installed, all options bypassed	10 MHz to 50 MHz	> 90 dB
	50 MHz to 500 MHz	> 105 dB
	500 MHz to 24 GHz	> 120 dB
	24 GHz to 40 GHz	> 110 dB
	40 GHz to 50 GHz	> 100 dB
	50 GHz to 67 GHz	> 90 dB
Insertion loss from port 1 (2) source in connector to port 1 (2)		
R&S®ZVAX-TRM with all options installed, all options bypassed	1 GHz to 10 GHz	< 8 dB, typ. 6 dB
	10 GHz to 20 GHz	< 12 dB, typ. 10 dB
	20 GHz to 40 GHz	< 17 dB, typ. 15 dB
	40 GHz to 50 GHz	< 19 dB, typ. 17 dB
	50 GHz to 67 GHz	< 22 dB, typ. 20 dB
Insertion loss port 3 (4) source in connector to port 3 (4) source out connector		
R&S®ZVAX-TRM with all options installed, all options bypassed	1 GHz to 10 GHz	< 7 dB, typ. 5 dB
	10 GHz to 20 GHz	< 9 dB, typ. 7 dB
	20 GHz to 40 GHz	< 13 dB, typ. 11 dB
	40 GHz to 50 GHz	< 15 dB, typ. 13 dB
	50 GHz to 67 GHz	< 17 dB, typ. 15 dB

Maximum power at port 1 and 2 <sup>1</sup>	10 MHz to 67 GHz	43 dBm	
Insertion loss port 1 (2) user source in to port 1 (2)			
	1 GHz to 10 GHz	typ. 2.5 dB	
	10 GHz to 25 GHz	typ. 3.5 dB	
	25 GHz to 40 GHz	typ. 4.5 dB	
	40 GHz to 50 GHz	typ. 5.5 dB	
	50 GHz to 67 GHz	typ. 6.5 dB	
Coupling factor		<b>measurement</b>	<b>reference</b>
	1 GHz to 10 GHz	typ. 12 dB	typ. 30 dB
	10 GHz to 25 GHz	typ. 14 dB	typ. 36 dB
	25 GHz to 40 GHz	typ. 18 dB	typ. 46 dB
	40 GHz to 50 GHz	typ. 20 dB	typ. 52 dB
Directivity	50 GHz to 67 GHz	typ. 26 dB	typ. 60 dB
	1 GHz to 10 GHz	typ. 14 dB	
	10 GHz to 25 GHz	typ. 14 dB	
	25 GHz to 40 GHz	typ. 12 dB	
	40 GHz to 50 GHz	typ. 10 dB	
	50 GHz to 67 GHz	typ. 8 dB	

<sup>1</sup> External attenuators and/or isolators may be necessary to prevent the R&S®ZVAX-TRM or the R&S®ZVA from being damaged.

## Options

<b>R&amp;S®ZVAX24/40/50/67B112 (and B134)</b>	amplifier at source ports 1 and 2 (and source ports 3 and 4)		
Output power port 1 and port 2			
R&S®ZVAX-TRM with all options installed, all options bypassed	nominal input power –5 dBm		
	500 MHz to 10 GHz	> –13 dBm	
	10 GHz to 20 GHz	> –17 dBm	
	20 GHz to 40 GHz	> –22 dBm	
	40 GHz to 50 GHz	> –24 dBm	
R&S®ZVAX-TRM with all options installed, option B112 active, all other options bypassed	nominal input power –5 dBm		
	500 MHz to 10 GHz	> 5 dBm	
	10 GHz to 20 GHz	> 1 dBm	
	20 GHz to 40 GHz	> –5 dBm	
	40 GHz to 50 GHz	> –10 dBm	
50 GHz to 67 GHz	> –18 dBm		
	Insertion gain port 1 (2) source in connector to port 1 (2)		
	R&S®ZVAX-TRM with all options installed, option B112 active, all other options bypassed	1 GHz to 10 GHz	> 10 dB, typ. 12 dB
		10 GHz to 20 GHz	> 5 dB, typ. 7 dB
		20 GHz to 40 GHz	> 0 dB, typ. 2 dB
40 GHz to 50 GHz		> –6 dB, typ. –3 dB	
50 GHz to 67 GHz		> –10 dB, typ. –8 dB	
Insertion gain port 3 (4) source in connector to port 3 (4) source out connector			
R&S®ZVAX-TRM with all options installed, option B134 active, all other options bypassed	1 GHz to 10 GHz	> 10 dB, typ. 13 dB	
	10 GHz to 20 GHz	> 6 dB, typ. 10 dB	
	20 GHz to 40 GHz	> 2 dB, typ. 8 dB	
	40 GHz to 50 GHz	> –3 dB, typ. 2 dB	
	50 GHz to 67 GHz	> –6 dB, typ. –2 dB	
Insertion gain of option B112 (B134)			
	1 GHz to 10 GHz	typ. 18 dB	
	10 GHz to 20 GHz	typ. 18 dB	
	20 GHz to 40 GHz	typ. 17 dB	
	40 GHz to 50 GHz	typ. 14 dB	
	50 GHz to 67 GHz	typ. 9 dB	

<b>R&amp;S ZVAX24/40/50/67B213 (and B224)</b>	internal combiner ports 1 and 3 (and ports 2 and 4)	
Insertion loss port 1 or 3 (2 or 4) source in connector to port 1 (2)		
R&S®ZVAX-TRM with all options installed, option B213 (B224) active, all other options bypassed	1 GHz to 10 GHz	< 15 dB, typ. 11 dB
	10 GHz to 20 GHz	< 20 dB, typ. 15 dB
	20 GHz to 40 GHz	< 26 dB, typ. 23 dB
	40 GHz to 50 GHz	< 30 dB, typ. 25 dB
	50 GHz to 67 GHz	< 36 dB, typ. 32 dB
Insertion loss of option B213 (B224)		
	1 GHz to 10 GHz	typ. 4 dB
	10 GHz to 20 GHz	typ. 5 dB
	20 GHz to 40 GHz	typ. 8 dB
	40 GHz to 50 GHz	typ. 9 dB
	50 GHz to 67 GHz	typ. 14 dB

<b>R&amp;S®ZVAX24/40/50/67B31 (and B32)</b>		low noise amplifier at port 1 (and port 2), operation limited to 50 GHz	
<b>Configuration A</b> port 1 (2) to port 1 (2) meas out connector, <b>Configuration B</b> port 1 (2) user meas in connector to port 1 (2) meas out connector			
Insertion gain	10 MHz to 1 GHz	configuration A typ. > 20 dB	configuration B typ. > 30 dB
	1 GHz to 20 GHz	typ. > 18 dB	typ. > 28 dB
	20 GHz to 40 GHz	typ. > 16 dB	typ. > 26 dB
	40 GHz to 45 GHz	typ. > 14 dB	typ. > 22 dB
	45 GHz to 50 GHz	typ. > 5 dB	typ. > 12 dB
Noise figure	10 MHz to 1 GHz	configuration A typ. < 30 dB	configuration B typ. < 15 dB
	1 GHz to 20 GHz	typ. < 22 dB	typ. < 12 dB
	20 GHz to 40 GHz	typ. < 25 dB	typ. < 15 dB
	40 GHz to 45 GHz	typ. < 30 dB	typ. < 20 dB
	45 GHz to 50 GHz	typ. < 35dB	typ. < 25 dB
Compression point (0.1 dB)	10 MHz to 1 GHz	configuration A typ. > -35 dBm	configuration B typ. > -45 dBm
	1 GHz to 20 GHz	typ. > -35 dBm	typ. > -45 dBm
	20 GHz to 40 GHz	typ. > -35 dBm	typ. > -45 dBm
	40 GHz to 45 GHz	typ. > -35 dBm	typ. > -45 dBm
	45 GHz to 50 GHz	typ. > -35 dBm	typ. > -45 dBm
Damage power		5 dBm	-10 dBm
Insertion gain of option B31 (B32)	1 GHz to 10 GHz	typ. 7 dB	
	10 GHz to 20 GHz	typ. 9 dB	
	20 GHz to 40 GHz	typ. 11 dB	
	40 GHz to 50 GHz	typ. 14 dB	

<b>R&amp;S®ZVAX24/40/50/67B712 (and B73)</b>		pulse modulator at source port 1 and 2 (and source port 3), operation limited to 60 GHz	
Insertion gain port 1 (3) source in connector to port 1 (2)			
R&S®ZVAX-TRM with all options installed, option B712 active, all other options bypassed	1 GHz to 10 GHz	< 15 dB, typ. 13 dB	
	10 GHz to 20 GHz	< 20 dB, typ. 18 dB	
	20 GHz to 40 GHz	< 30 dB, typ. 28 dB	
	40 GHz to 50 GHz	< 34 dB, typ. 32 dB	
	50 GHz to 60 GHz	< 45 dB, typ. 40 dB	
Insertion gain port 3 source in connector to port 3 source out connector			
R&S®ZVAX-TRM with all options installed, option B73 active, all other options bypassed	1 GHz to 10 GHz	< 15 dB, typ. 13 dB	
	10 GHz to 20 GHz	< 20 dB, typ. 18 dB	
	20 GHz to 40 GHz	< 30 dB, typ. 25 dB	
	40 GHz to 50 GHz	< 34 dB, typ. 28 dB	
	50 GHz to 60 GHz	< 45 dB, typ. 40 dB	
Insertion loss of option B73	1 GHz to 10 GHz	typ. 7 dB	
	10 GHz to 20 GHz	typ. 9 dB	
	20 GHz to 40 GHz	typ. 11 dB.	
	40 GHz to 50 GHz	typ. 14 dB	
	50 GHz to 60 GHz	typ. 18 dB	
On-off ratio	1 GHz to 10 GHz	typ. > 60 dB	
	10 GHz to 25 GHz	typ. > 55 dB	
	25 GHz to 40 GHz	typ. > 35 dB	
	40 GHz to 50 GHz	typ. > 30 dB	
	50 GHz to 60 GHz	typ. > 25 dB	
Rise/fall time		< 5 ns, typ. 1 ns	
Pulse droop		< 0.5 dB, typ. 0.05 dB	
Delay trigger to RF pulse	internal pulse generator	< 25 ns	

# R&S®ZVAX-TRM topology

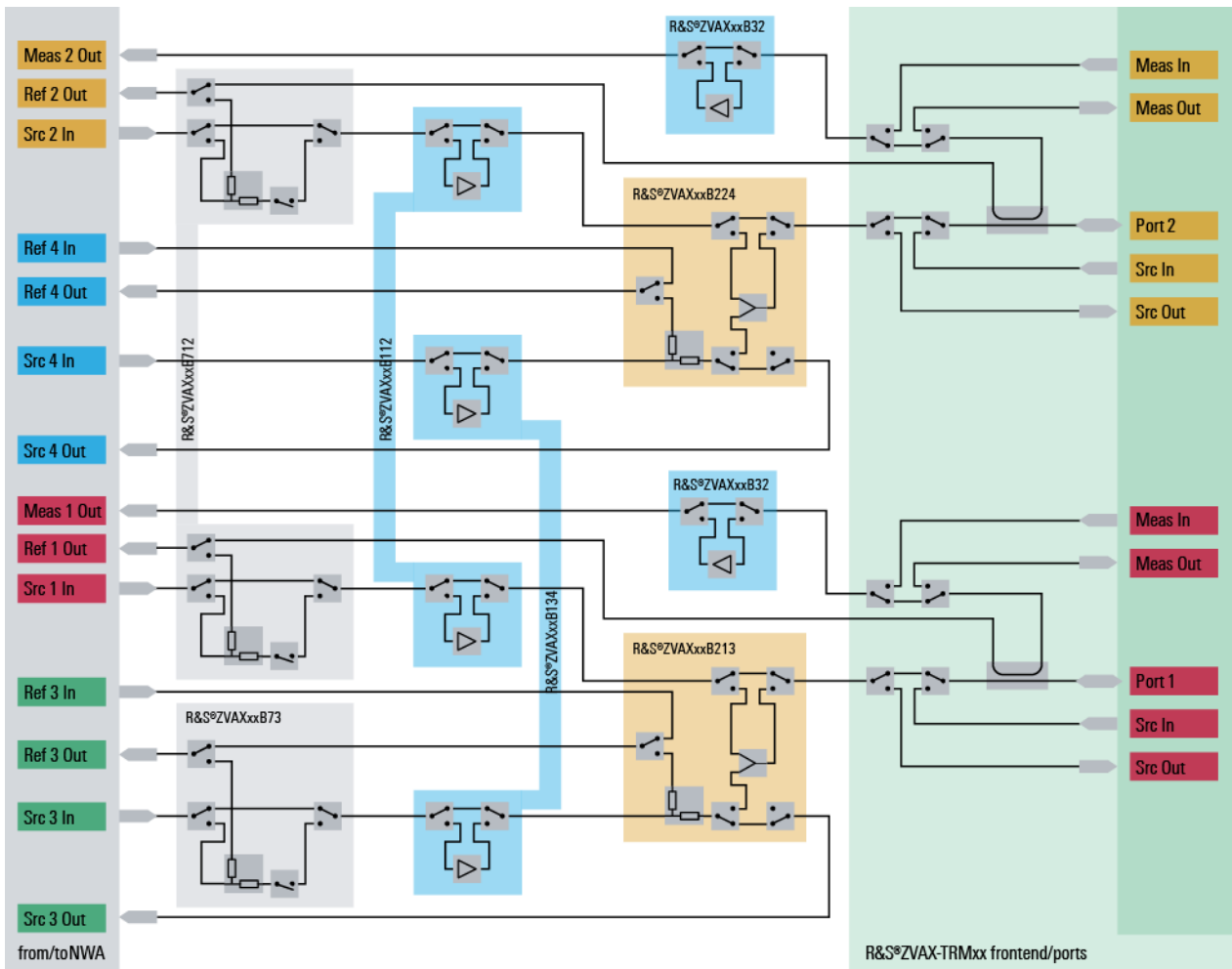

## Dimensions (in mm)

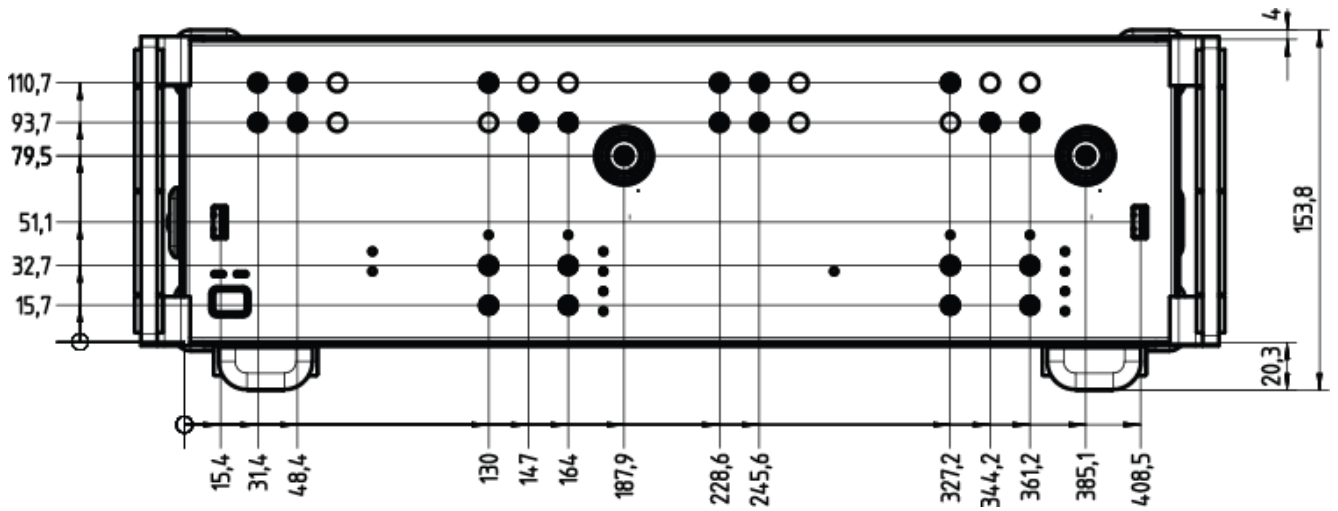

Front view of the R&S®ZVAX-TRM.

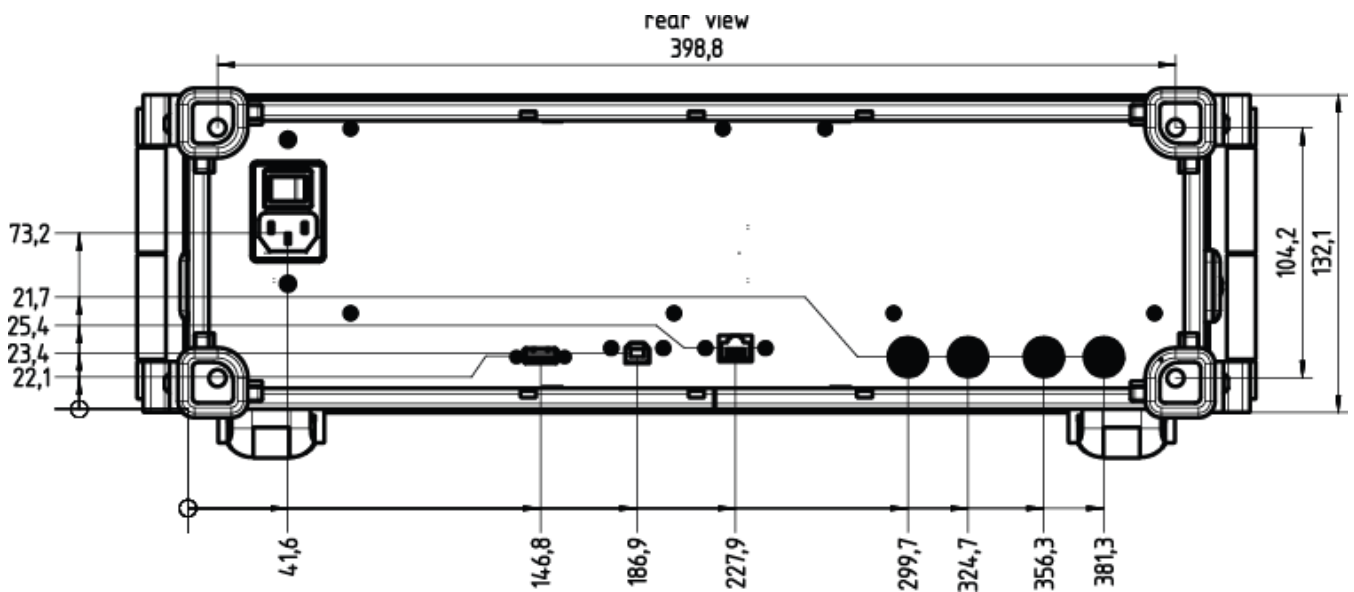

Rear view of the R&S®ZVAX-TRM.



## Connectors

General data for auxiliary RF inputs and outputs (unless otherwise specified)

Connector type, base unit interconnect	R&S®ZVAX-TRM24	2.92 mm, female
	R&S®ZVAX-TRM40	2.92 mm, female
	R&S®ZVAX-TRM50	1.85 mm, female
	R&S®ZVAX-TRM67	1.85 mm, female
Impedance		50 $\Omega$
Maximum nominal input power		20 dBm
Damage power		27 dBm
Damage DC voltage		0 V

## Front panel connectors

Auxiliary inputs are sorted in the order of appearance on the front panel. The connector type is specified in the table above.

PORT 3 SOURCE IN	input for the source signal of port 3
PORT 3 SOURCE OUT	output for the source signal of port 3
PORT 3 REF IN	input for the reference signal of port 3
PORT 3 REF OUT	output for the reference signal of port 3
PORT 1 SOURCE IN	input for the source signal of port 1
PORT 1 SOURCE OUT	output for the source signal of port 1
PORT 1 REF OUT	output for the reference signal of port 1
PORT 1 MEAS OUT	output for the measurement signal of port 1
PORT 1 USER SOURCE IN	input for the user specific source signal of port 1
PORT 1 USER SOURCE OUT	output for the user specific source signal of port 1
PORT 1 USER MEAS IN	input for the user specific measurement signal of port 1
PORT 1 USER MEAS OUT	output for the user specific measurement signal of port 1
PORT 4 SOURCE IN	input for the source signal of port 4
PORT 4 SOURCE OUT	output for the source signal of port 4
PORT 4 REF IN	input for the reference signal of port 4
PORT 4 REF OUT	output for the reference signal of port 4
PORT 2 SOURCE IN	input for the source signal of port 2
PORT 2 SOURCE OUT	output for the source signal of port 2
PORT 2 REF OUT	output for the reference signal of port 2
PORT 2 MEAS OUT	output for the measurement signal of port 2
PORT 2 USER SOURCE IN	input for the user specific source signal of port 2
PORT 2 USER SOURCE OUT	output for the user specific source signal of port 2
PORT 2 USER MEAS IN	input for the user specific measurement signal of port 2
PORT 2 USER MEAS OUT	output for the user specific measurement signal of port 2

<b>USB</b>	two universal serial bus connectors type A for USB devices (USB 2.0)
------------	--

<b>PORT 1 and PORT 2</b>		test port 1 and 2
Connector type	R&S®ZVAX-TRM24	3.5 mm, male
	R&S®ZVAX-TRM40	2.92 mm, male
	R&S®ZVAX-TRM50	2.4 mm, male
	R&S®ZVAX-TRM67	1.85 mm, male
Impedance		50 Ω
Maximum nominal input power <sup>2</sup>		43 dBm
Damage power		45 dBm
Maximum nominal DC input voltage		0 V

<sup>2</sup> External attenuators and/or isolators may be necessary to prevent the R&S®ZVAX-TRM or the R&S®ZVA from being damaged.

## Rear panel connectors

<b>USB FROM ZVA</b>		universal serial bus connector type B for connection to the R&S®ZVA (USB 2.0)
<b>USB</b>		universal serial bus connectors type A for USB devices (USB 2.0)
<b>CASCADE IN</b>		input for pulse and sync LVDS signals from pulse generator of the R&S®ZVA, for connection to the CASCADE jack of the R&S®ZVA, connector type 8P8C western modular jack
Not connected	pin 1, 2, 3, 6	
Pulse_B and Pulse_A	pin 4 and 5 (input)	pulse signal from R&S®ZVA
Sync_B and Sync_A	pin 7 and 8 (input)	sync signal from R&S®ZVA
GND	pin 9 and 10	signal ground
<b>EXT PULSE GENERATOR IN 1, 2</b>		inputs for pulse signals from external pulse generator
Connector type		BNC, female
TTL signal		TTL/LVTTL compatible
Low	state: off	≤ 0.8 V
High	state: on	≥ 2.0 V
DC damage level		5.5 V
Polarity		positive
Input impedance		50 Ω (nom.)
<b>PULSE GENERATOR OUT 1, 2</b>		outputs for pulse signals
Connector type		BNC, female
TTL signal		TTL/LVTTL compatible
Low	state: off	≤ 0.8 V
High	state: on	≥ 2.0 V ≤ 5 V with 50 Ω load
DC damage level		5.5 V
Polarity		positive
Output impedance		50 Ω (nom.)

## General data

Temperature loading	in line with IEC 60068-2-1 and IEC 60068-2-2	
	operating temperature range	+5 °C to +40 °C
	permissible temperature range	+5 °C to +40 °C
	storage temperature range	-40 °C to +70 °C
Damp heat		+40 °C at 95 % rel. humidity, in line with IEC 60068-2-30
Altitude	operating environment	max. 3000 m
Mechanical resistance	vibration, sinusoidal	5 Hz to 150 Hz, in line with IEC 60068-2-6
	vibration, random	10 Hz to 300 Hz, in line with IEC 60068-2-64
	shock	40 g shock spectrum, in line with IEC 60068-2-27, MIL-STD-810
Calibration interval		2 years
EMC, RF emission	In line with EN 61000-6-4, operation is not covered in residential, commercial and business areas nor in small-size companies. Thus, the instrument must not be operated in residential, commercial and business areas nor in small-size companies unless additional measures are taken to ensure that EN 61000-6-3 is met.	in line with CISPR 11/EN 55011 group 1 class A (for a shielded test setup); The instrument complies with the emission requirements stipulated by EN 55011 class A. This means that the instrument is suitable for use in industrial environments.
EMC, other emissions and immunity		in line with IEC/EN 61326, emission class B (residential environment), immunity industrial environment (excluding operating frequency)
Safety		IEC 61010-1, EN 61010-1, UL 61010-1, CSA-C22.2 No. 61010-1
Power supply		100 V to 240 V AC with tolerance $\pm 10\%$ , 50 Hz to 60 Hz and 400 Hz with tolerance $\pm 5\%$
Input current		1.7 A max. at 100 V AC, 0.8 A max. at 240 V AC
Test mark		VDE, GS, CSA, CSA-NRTL/C, CE conformity mark
Dimensions	W x H x D	465 mm x 154 mm x 495 mm (18.31 in x 6.06 in x 19.49 in)
Weight		9 kg (20 lb)
Shipping weight		16 kg (35 lb)

## Ordering information

Designation	Type	Order No.
<b>Base unit</b>		
Extension Unit	R&S®ZVAX-TRM24	1322.6500.24
	R&S®ZVAX-TRM40	1322.6500.40
	R&S®ZVAX-TRM50	1322.6500.50
	R&S®ZVAX-TRM67	1322.6500.67
<b>Options</b>		
Amplifier at Source Port 1 and 2	R&S®ZVAX24B112	1322.6981.24
	R&S®ZVAX40B112	1322.6981.40
	R&S®ZVAX50B112	1322.6981.50
	R&S®ZVAX67B112	1322.6981.67
Amplifier at Source Port 3 and 4	R&S®ZVAX24B134	1322.6998.24
	R&S®ZVAX40B134	1322.6998.40
	R&S®ZVAX50B134	1322.6998.50
	R&S®ZVAX67B134	1322.6998.67
Internal Combiner, Port 1 and 3	R&S®ZVAX24B213	1322.7007.24
	R&S®ZVAX40B213	1322.7007.40
	R&S®ZVAX50B213	1322.7007.50
	R&S®ZVAX67B213	1322.7007.67
Internal Combiner, Port 2 and 4	R&S®ZVAX24B224	1322.7013.24
	R&S®ZVAX40B224	1322.7013.40
	R&S®ZVAX50B224	1322.7013.50
	R&S®ZVAX67B224	1322.7013.67
Pulse Modulator at Source Port 1 and 2	R&S®ZVAX24B712	1322.6969.24
	R&S®ZVAX40B712	1322.6969.40
	R&S®ZVAX50B712	1322.6969.50
	R&S®ZVAX67B712	1322.6969.67
Pulse Modulator at Source Port 3	R&S®ZVAX24B73	1322.6975.24
	R&S®ZVAX40B73	1322.6975.40
	R&S®ZVAX50B73	1322.6975.50
	R&S®ZVAX67B73	1322.6975.67
Low Noise Amplifier at Port 1	R&S®ZVAX24B31	1322.7020.24
	R&S®ZVAX40B31	1322.7020.40
	R&S®ZVAX50B31	1322.7020.50
	R&S®ZVAX67B31	1322.7020.67
Low Noise Amplifier at Port 2	R&S®ZVAX24B32	1322.7036.24
	R&S®ZVAX40B32	1322.7036.40
	R&S®ZVAX50B32	1322.7036.50
	R&S®ZVAX67B32	1322.7036.67
Rack Mount Kit for R&S®ZVA 19" adapter, 6 HU	R&S®ZZA-611	1096.3302.00
Rack Mount Kit for R&S®ZVAX-TRM24 (includes a set of shorter RF rigid interconnection cables, required when VNA mounted without feet)	R&S®ZZA-ZVAX	1325.1422.24
Rack Mount Kit for R&S®ZVAX-TRM40 (includes a set of shorter RF rigid interconnection cables, required when VNA mounted without feet)	R&S®ZZA-ZVAX	1325.1422.40
Rack Mount Kit for R&S®ZVAX-TRM50 (includes a set of shorter RF rigid interconnection cables, required when VNA mounted without feet)	R&S®ZZA-ZVAX	1325.1422.50
Rack Mount Kit for R&S®ZVAX-TRM67 (includes a set of shorter RF rigid interconnection cables, required when VNA mounted without feet)	R&S®ZZA-ZVAX	1325.1422.67

<b>Service options</b>		
Extended Warranty, one year	R&S®WE1	Please contact your local Rohde & Schwarz sales office.
Extended Warranty, two years	R&S®WE2	
Extended Warranty, three years	R&S®WE3	
Extended Warranty, four years	R&S®WE4	
Extended Warranty with Calibration Coverage, one year	R&S®CW1	
Extended Warranty with Calibration Coverage, two years	R&S®CW2	
Extended Warranty with Calibration Coverage, three years	R&S®CW3	
Extended Warranty with Calibration Coverage, four years	R&S®CW4	

**Extended warranty with a term of one to four years (WE1 to WE4)**

Repairs carried out during the contract term are free of charge <sup>3</sup>. Necessary calibration and adjustments carried out during repairs are also covered. Simply contact the forwarding agent we name; your product will be picked up free of charge and returned to you in top condition a couple of days later.

**Extended warranty with calibration (CW1 to CW4)**

Enhance your extended warranty by adding calibration coverage at a package price. This package ensures that your Rohde & Schwarz product is regularly calibrated, inspected and maintained during the term of the contract. It includes all repairs <sup>3</sup> and calibration at the recommended intervals as well as any calibration carried out during repairs or option upgrades.

---

<sup>3</sup> Excluding defects caused by incorrect operation or handling and force majeure. Wear-and-tear parts are not included.



## Service that adds value

- | Worldwide
- | Local and personalized
- | Customized and flexible
- | Uncompromising quality
- | Long-term dependability

## About Rohde & Schwarz

The Rohde & Schwarz electronics group offers innovative solutions in the following business fields: test and measurement, broadcast and media, secure communications, cybersecurity, radiomonitoring and radiolocation. Founded more than 80 years ago, this independent company has an extensive sales and service network and is present in more than 70 countries. The electronics group is among the world market leaders in its established business fields. The company is headquartered in Munich, Germany. It also has regional headquarters in Singapore, Columbia and Maryland, USA, to manage its operations in these regions.

## Sustainable product design

- | Environmental compatibility and eco-footprint
- | Energy efficiency and low emissions
- | Longevity and optimized total cost of ownership

Certified Quality Management

ISO 9001

Certified Environmental Management

ISO 14001

## Rohde & Schwarz GmbH & Co. KG

[www.rohde-schwarz.com](http://www.rohde-schwarz.com)

## Regional contact

- | Europe, Africa, Middle East | +49 89 4129 12345  
[customersupport@rohde-schwarz.com](mailto:customersupport@rohde-schwarz.com)
- | North America | 1 888 TEST RSA (1 888 837 87 72)  
[customer.support@rsa.rohde-schwarz.com](mailto:customer.support@rsa.rohde-schwarz.com)
- | Latin America | +1 410 910 79 88  
[customersupport.la@rohde-schwarz.com](mailto:customersupport.la@rohde-schwarz.com)
- | Asia Pacific | +65 65 13 04 88  
[customersupport.asia@rohde-schwarz.com](mailto:customersupport.asia@rohde-schwarz.com)
- | China | +86 800 810 82 28 | +86 400 650 58 96  
[customersupport.china@rohde-schwarz.com](mailto:customersupport.china@rohde-schwarz.com)

R&S® is a registered trademark of Rohde & Schwarz GmbH & Co. KG

Trade names are trademarks of the owners

PD 3607.0530.22 | Version 02.00 | June 2015 (as)

R&S®ZVAX-TRM Extension Unit

Data without tolerance limits is not binding | Subject to change

© 2014 - 2015 Rohde & Schwarz GmbH & Co. KG | 81671 Munich, Germany



3607053022