

# HIOKI

## SM-8200 SERIES SUPER MEGOHMMETER



**SUPER MEGOHMMETER SM-8200 SERIES**



Large LCD digital/analog display  
Timer, comparator, remote start & communication functions fully-loaded



ISO 9001  
JMI-0216



ISO 14001  
JQA-E-90091



[www.hioki.com](http://www.hioki.com)

HIOKI company overview, new products, environmental considerations and other information are available on our website.

- Digital numeric readout with virtual analog display. Easy-to-use combined digital-analog models\*<sup>1</sup>
- Timer, comparator, remote start and command functions included as standard features to support new applications\*<sup>1</sup>
- Many safety-enhancing features

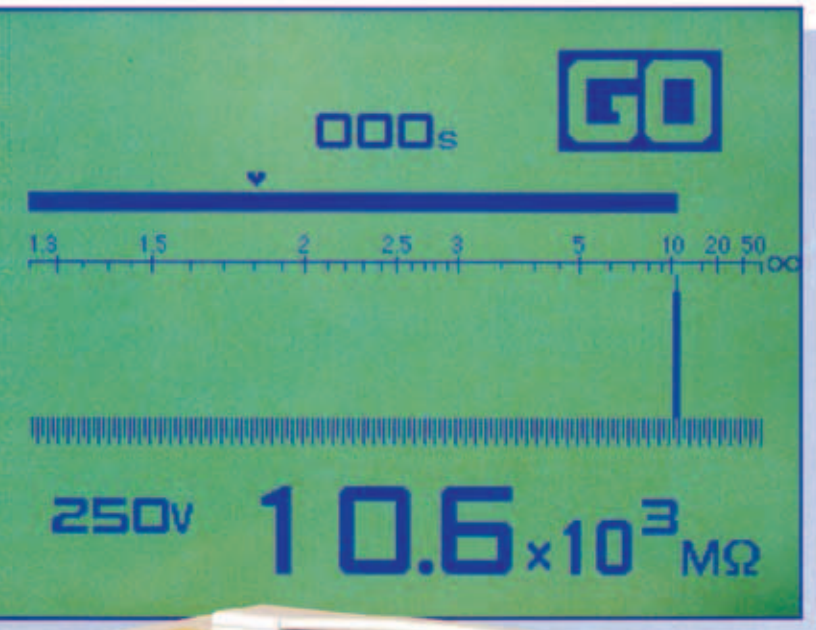

### Display Features

- 1- Clear, three-mode liquid crystal display\*<sup>1</sup>  
Bright LCD simultaneously displays data in three modes: quasi-bar-graph, virtual needle and numeric values.
- 2- Clear graduated scale and precise data reading\*<sup>1</sup>  
The one-line graduated scale is always visible, and scales automatically according to the selected measurement voltage. Data is held on the display after measuring, so there is no hurry to read it. The numeric readout displays measured values at maximum resolution.
- 3- Enhanced response speed and reliability\*<sup>1</sup>  
Reliability is enhanced because, unlike analog meters, the LCD has no moving parts, and the virtual needle responds seven times faster than a mechanical needle. Installation in automated systems is supported.

### Usability Features

- 1- Timer function included as a standard feature\*<sup>1</sup>  
The need for counting complicated measurement time (by stopwatch) is eliminated. Timer settings are retained in internal memory even when power is turned off.
- 2- Comparator functions included as a standard feature\*<sup>1</sup>  
Easy-to-use GO/NO-GO (Pass/Fail) decisions  
NO-GO (Fail) decisions can be indicated by an alarm sound simultaneously with contact output. Comparator settings are retained even when power is turned off.
- 3- Remote Start function included as a standard feature\*<sup>1</sup>  
Measurement can be started hands-free, using a footswitch or trigger signal.
- 4- Compact and lightweight\*<sup>1</sup>  
16% lighter and 22% more compact than previous models.  
The small attached stand makes operation even easier: panel buttons are easy to press and the display is easy to see.

# SM-8200 Series SUPER MEGOHMMETERS

Digital-Analog Models: SM-8213/8215/8220  
Analog Model: SM-8216

## Safety Features

### 1- Measurement is disabled unless the measurement leads are connected.\*1

A shock hazard can occur if a measurement probe is inadvertently disconnected or pulled out while high voltage is being output during measurement.

This danger can be even greater if the black measurement probe is disconnected.

To ensure safety even when the black probe is disconnected, a measurement lead detection system is incorporated at the probe receptacles.

### 2- Interlock(HV-EN)provided as a standard feature

The HV-EN (interlock) function is linked with the footswitch, open/close switch on the test jig and contact signal from an automated testing machine, so that measurement voltage is applied only when conditions are safe.

### 3- Measurement stops in a discharged state\*1

When measurement is finished or aborted by switch action, the red and black terminals are discharged through 100 kΩ. This results in safer measurements by reducing the possibility of electric shock accidents from residual charge on capacitive DUTs.

When measurement is intentionally aborted, measurement voltage is shut off in about 0.1 second.

### 4- Function to prevent unintentional start\*1

To avoid electric shock accidents in the event that the Start button is accidentally pressed when the DUT is not securely connected, the Start button must be held for at least one-half second before measurement starts.

## Controls and Connectors



### Front Panel

- 1 Display Screen
- 2 POWER Switch
- 3 V.OUT Lamp
- 4 RX Terminal
- 5 SELECT Switch
- 6 DOWN Switch
- 7 UP Switch
- 8 CHARGE Switch
- 9 MEASURE/DISCHARGE Switch
- 10 RANGE Switch
- 11 VOLTAGE Switch



### Rear Panel

- 12 VOLTAGE SELECTOR\*2
- 13 AC LINE
- 14 TIME LAG FUSE
- 15 GND Terminal
- 16 Input/Output Terminals
- 17 HV-EN Connector (Interlock)
- 18 RS-232C Connector

\*2. When switching between 100 V/120 V and 220 V/240 V supply voltage, an internal fuse must be changed. Please contact HIOKI or your nearest HIOKI distributor.

## Computer-Friendly Features

### 1- RS-232C included as a standard feature\*1

A computer can be connected via RS-232C serial interface.

## Function Expanding Features

### 1- An abundance of electrode types

All models support a wide variety of electrodes.

### 2- Special-purpose options enhance functionality

Special-purpose options include 1/R DC output, resistivity-proportional DC output, guard tips and alarm devices (Except for analog Model SM-8216 ) to enhance functionality.



These models include both digital numeric and virtual analog level displays. Support for a broad range of high-applied-voltage and high resistance measurements.

### SM-8213

For low voltage from 5 to 100 V DC and charge current up to 50 mA



The SM-8213 is ideal for insulation measurements of modern low-voltage electronic components.

Easy-to-see simultaneous digital numeric and analog graduated scale displays.

The maximum 50 mA current capability, which is the highest in this series, provides stable measurements of even high-value capacitors.

To support measurement by computer, communication functions via RS-232C are included as a standard feature.

#### Features

- Easy-to-read digital numeric and virtual analog LCD
- 50 mA maximum output current, the highest in the series
- Timer, comparator, remote start, Interlock(HV-EN) and RS-232C functions included as standard features
- Functions expandable by options
- A broad selection of electrodes support measuring a wide variety of objects

### SM-8215

Standard model insulation meter with measurement voltage settable up to 1,000 V



The SM-8215 is a basic insulation meter that carries on our company's tradition of ultra-high insulation meters.

It is used in various fields including electronic components and materials, and for insulation measurements on completed electrical products.

The liquid crystal display includes both easy-to-read digital and intuitive analog level indicators. Convenient standard features include timer, comparator, remote start and Interlock(HV-EN) functions.

Measures time characteristic and voltage characteristic of insulators. To support measurement by computer, communication functions via RS-232C are included as a standard feature.

#### Features

- Easy-to-read digital numeric and virtual analog LCD
- Timer, comparator, remote start, Interlock(HV-EN) and RS-232C functions included as standard features
- Functions expandable by options
- A broad selection of electrodes support measuring a wide variety of objects

### SM-8220

Measures up to  $2 \times 10^{16} \Omega$ , the highest range available in our super megohmmeters



The SM-8220 is a top-of-the-line super megohmmeter that can measure up to  $2 \times 10^{16} \Omega$  (at 1,000 V). The combined digital and analog display is the latest evolutionary step combining our line of super megohmmeters with the newest technology. This powerful super megohmmeter handles a variety of insulation measurements, from those requiring low to high measurement voltages and measuring from low to ultra-high resistance. Convenient standard features include timer, comparator, remote start and Interlock(HV-EN) functions. These enable safer and more reliable measurement of volume and surface resistivity using flat sample test fixtures (such as the SME-8310).

RS-232C communication functions required for measurement by computer are included as a standard feature.

#### Features

- The highest measurement range in the series: up to  $2 \times 10^{16} \Omega$
- Measurement voltage can be set from 10 to 1,000 V
- Easy-to-read digital numeric and virtual analog LCD
- Timer, comparator, remote start, Interlock(HV-EN) and RS-232C functions included as standard features
- Functions expandable by options
- A broad selection of electrodes support measuring a wide variety of objects

## Analog Meter System Unique in the Series

### SM-8216

Analog meter system  
Measures up to  $2 \times 10^{13} \Omega$



The SM-8216 is an analog super megohmmeter that is unique in the series.

For safety considerations, Interlock(HV-EN) is included as a standard feature.

#### Features

- Charge, discharge and HV-EN functions are included as standard features
- Functions expandable by options
- A broad selection of electrodes support measuring a wide variety of objects

# Specifications

Model	SM-8213	SM-8215	SM-8220	SM-8216	
Measurement voltage and measurement range	5 V	$2.5 \times 10^4 \sim 1 \times 10^{11} \Omega$			
	10 V	$5 \times 10^4 \sim 2 \times 10^{11} \Omega$	$5 \times 10^4 \sim 2 \times 10^{14} \Omega$	$5 \times 10^4 \sim 2 \times 10^{11} \Omega$	
	15 V	$7.5 \times 10^4 \sim 3 \times 10^{11} \Omega$			
	25 V	$1.25 \times 10^5 \sim 5 \times 10^{11} \Omega$			
	50 V	$2.5 \times 10^5 \sim 1 \times 10^{12} \Omega$	$2.5 \times 10^5 \sim 1 \times 10^{12} \Omega$	$1.25 \times 10^5 \sim 5 \times 10^{14} \Omega$	$1.25 \times 10^5 \sim 5 \times 10^{11} \Omega$
	100 V	$5 \times 10^5 \sim 2 \times 10^{12} \Omega$	$5 \times 10^5 \sim 2 \times 10^{12} \Omega$	$5 \times 10^5 \sim 2 \times 10^{15} \Omega$	$2.5 \times 10^5 \sim 1 \times 10^{12} \Omega$
	250 V		$1.25 \times 10^6 \sim 5 \times 10^{12} \Omega$	$1.25 \times 10^6 \sim 5 \times 10^{15} \Omega$	$1.25 \times 10^6 \sim 5 \times 10^{12} \Omega$
	500 V		$2.5 \times 10^6 \sim 1 \times 10^{13} \Omega$	$2.5 \times 10^6 \sim 1 \times 10^{16} \Omega$	$2.5 \times 10^6 \sim 1 \times 10^{13} \Omega$
1,000 V		$5 \times 10^6 \sim 2 \times 10^{13} \Omega$	$5 \times 10^6 \sim 2 \times 10^{16} \Omega$	$5 \times 10^6 \sim 2 \times 10^{13} \Omega$	
Measurement voltage accuracy	±3% of setting value				
Output current	Max. 50 mA	Max. 2 mA			
Measurement accuracy	±10% (ten times the minimum value for each range at 20 °C) Except for the 10 <sup>8</sup> range of the SM-8220, which is ±20%				
Display type	LCD (Digital numeric & virtual analog display)			Analog meter	
Standard features	Timer (1 to 999s), Comparator, Remote Start, HV-EN (Interlock)			HV-EN (Interlock)	
Interface	RS-232C, Comparator output (open-collector)			—	
Operating temp. range	0 to 40 °C		5 to 35 °C	0 to 40 °C	
Operating humidity range	80% or less				
Supply voltage	100, 120, 220 or 240 V AC ±10% (specify when ordering)				
Supply frequency	50 or 60 Hz				
Power consumption	Approx. 25 VA			Approx. 20 VA	
External dimensions	Approx. 284W × 139H × 215D mm			Approx. 280W × 190H × 222D mm	
Weight	Approx. 4.3 kg			Approx. 5 kg	

**Supplied Accessories** Measurement Leads with Test Probes Length 1 m (Red) OGE0002.....1 pc. Power Cord .....1 pc. Instruction Manual .....1 pc.  
Measurement Leads with Test Probes Length 1 m (Black) OGE0001.....1 pc.

# Application Map

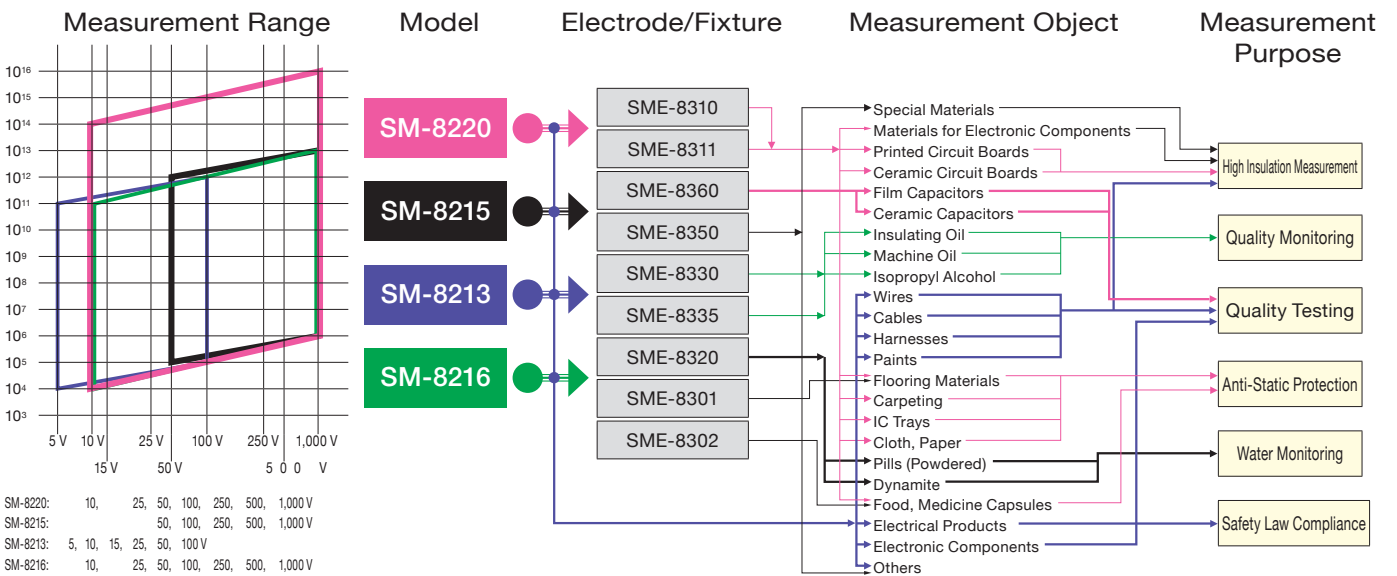

# Options (● indicates compatibility)

Model	SM-8213	SM-8215	SM-8220	SM-8216
DC Output (1/R) (RI-8000)*	●	●	●	●
DC Output (Resistivity-Proportional Output) (RP-8000)*	●	●	●	●

\* Factory-installed options - specify at time of order

# Reliably Conduct Hard-To-Make Measurements

## ELECTRODE and SHIELDING BOX (options)

### SURFACE/VOLUME RESISTANCE MEASUREMENT ELECTRODE SM9001



- Electrodes compliant with the JIS C 2170 and IEC 61340-2-3 standards
- Measurement voltage up to 1,000 V, and measurement resistance up to  $10^{13} \Omega$
- Surface and volume resistance of sheets and films can be measured just as they are without the need to cut samples
- Measure the surface resistance of antistatic flooring and molded products

Note: When used in combination with the DSM-8104 or SM-8220 super megohm meter, Measurement resistance range\*:  $10^2$  to  $10^{13} \Omega$

(\* When using the SM-8220:  $5 \times 10^4$  to  $10^{13} \Omega$ )

Dimensions:  $\phi$  100mm (3.94in)  $\times$  223mm (8.78in), Mass: 2.5 kg (88.2oz)

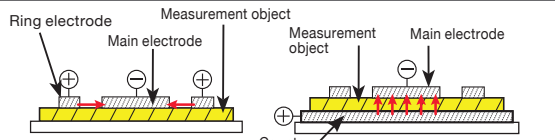

#### Surface Resistance Measurement

Measure the surface resistance between the main electrode and ring electrode of the main body electrode.

#### Volume Resistance Measurement

Measure the volume resistance of the sample sandwiched between the main electrode and counter-electrode.

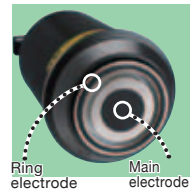

### VERIFICATION FIXTURE FOR SURFACE RESISTANCE MEASUREMENT SM9002

The SM9002 Verification Fixture for Surface Resistance Measurement (option) allows you to check the operation of the electrode to increase the reliability of measurement results.



### Electrode for surface resistance SME-8301



Surface resistance can be easily measured by simple pushing the electrode against the specimen. It measures surface resistance of anti-static related goods in combination of mainly SM-8213.

Dimensions:  $\phi$  60mm (2.36in)  $\times$  50mm (1.97in), Lead length 1m (3.28ft)

### Electrode for surface resistance SME-8302



An electrode distance: 4mm (0.16in)  
Dimensions:  $\phi$  40mm (1.57in)  $\times$  115mm (4.53in),  
Lead length 1m (3.28ft)

This is an electrode for surface resistance, when sample is curved shape such as, resin and rubber processed goods, TV cathode tube or sample is small. Surface resistance can be measured by pressing the rubber tips at the tip onto the sample. Electrode interval is 10mm and up to  $10^{10} \Omega$  can be measured.

### Electrode for plate sample SME-8310

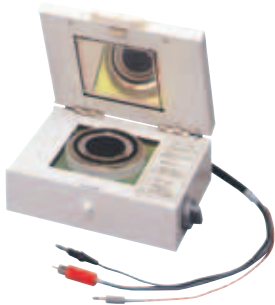

Sample of 100mm square by up to 8mm in thickness is measurable. The main electrode dia. is 50mm and inner & outer dia. of ring electrode are 70mm & 80mm respectively. Meas. voltage becomes "OFF" while the lid is open to ensure safety. A selector switch allows selection of voltage or surface resistivity. Electrodes are compliant with the JIS K 6911.

Dimensions: 215mm (8.46in) W  $\times$  78mm (3.07in)H  $\times$  165mm (6.50in)D, Lead length 75cm (2.46ft)

### Electrode for plate SME-8311

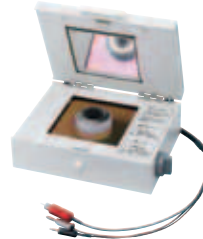

Dimensions: 215mm (8.46in) W  $\times$  78mm (3.07in)H  $\times$  165mm (6.50in)D, Lead length 75cm (2.46ft)

Sample of 40~100mm square by up to 8mm in thickness is measurable. The main electrode dia. is 19.6mm and inner & outer dia. of ring electrode are 24.1mm & 28.8mm respectively. Meas. voltage becomes "OFF" while the lid is open to ensure safety. The fundamental specifications are the same as SME-8310.

### Weight electrode SME-8320

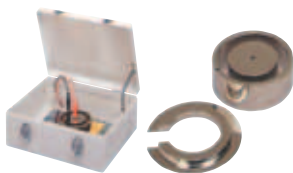

Included: Banana clips  $\times$  2  
Photo is Combination with Shield box SME-8350

This is an electrode for plate sample for use together with SME-8350 shield box. This electrode enables extremely easy measurement of surface resistivity and volume of sample with coarse surface such as carpets, etc. The main electrode dia. is 50mm, and the ring electrode inner-dia. and outer-dia. are 70mm and 80mm respectively.

### Shield box SME-8350



Included rubber sheet

Dimensions: 250mm (9.84in) W  $\times$  100mm (3.94in)H  $\times$  200mm (7.87in)D, Lead length 80cm (2.62ft)

### Electrode for liquid sample SME-8330



Included: Connection cable Red/ Black each 1, 60cm (1.97ft)

Dimensions:  $\phi$  36mm (1.42in)  $\times$  140mm (5.51in)

This is an electrode for liquid sample which is electrically guarded. Total volume is 25ml. Capacitance between main and counter electrode is approx. 45pF. Electrode constant is approx. 500cm. Distance between both electrodes is 1mm. Outer dia. is 36mm, height is approx. 140mm. Resistance up to  $10^{10} \Omega$  (at 1000V) can be measured when this electrode is used together with SM-8216.

Note: Included the inspection result sheet

### Electrode for chip capacitor SME-8360



Dimensions: 200mm (7.87in) W  $\times$  520mm (2.05in)H  $\times$  150mm (5.91in)D, Lead length 85cm (2.79ft)

For measurement of resistance of tip capacitor, with adjustable jig from 0mm to 11mm. When connected to the meter by interlock cable, meas. voltage becomes "OFF" while the lid is open to ensure safety.

### Standard resistor box SR-2



Dimensions: 270mm (10.63in) W  $\times$  90mm (3.54in)H  $\times$  195mm (7.68in)D

This is a resistor box for calibration of the super megohmmeters. Max. voltage is 1,000VDC and resistor value covers from 10M $\Omega$  to 10,000M $\Omega$  in 24 points.

Note: Included the inspection result sheet

# Megohmmeters

Super megohmmeters are a special type of ohmmeter intended to measure extremely high resistances by applying a specific voltage for the measurement, and so are treated differently from general-purpose ohmmeters. Also, almost all applications for insulation meters are for measuring the level of resistance, rather than for measuring a particular value of resistance. There are two general types of megohmmeters: portable insulation meters used at worksites, and bench-top megohmmeters used in research laboratories and in factory testing. We call these models 'super' megohmmeters because of their extreme performance capabilities, and we are proud to offer some of the best in the world.

● Our combined digital- and analog-display megohmmeter series consists of three models: the **SM-8213** for low voltage measurement requirements such as semiconductor circuit insulation resistance, the **SM-8215** for standard applications using measurement voltage up to 1,000 V, and the **SM-8220** for ultra-high insulation measurements.

## SM-8220

Supports measurements up to  $2 \times 10^{16} \Omega$ , the highest range available in our super megohmmeter line



● Available analog display model includes the **SM-8216**, which provides measurement voltage up to 1,000 V.

## SM-8216

Analog Meter with  $2 \times 10^{13} \Omega$  Measurement Range



● The digital model DSM-8104 is ideal for fast, accurate measurement of capacitive insulation resistance in objects such as capacitors. It includes GP-IB and handler interfaces and a contact check function to support automatic measurement and system integration.

## DSM-8104



### High-Speed Measurement by Charging with the Charge Terminal

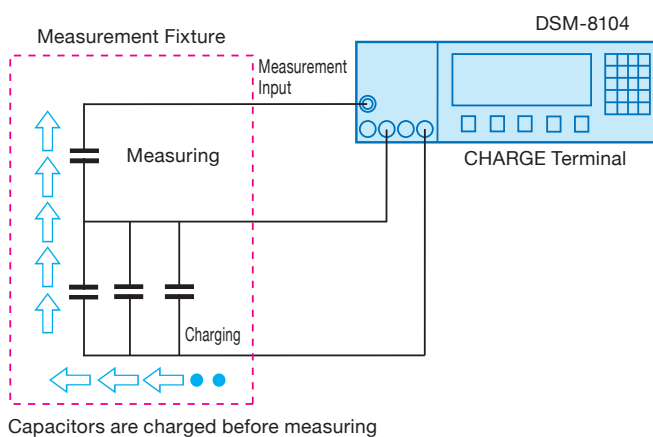

### Researching Insulation Material using an Electrode Combination

● Evaluating insulating materials using the SME-8310 Flat Sample Test Fixture.



### Testing Withstand Voltage of Semiconductor Thin Film (Insulation Breakdown)

- High-sensitivity current measurement is used for withstand voltage testing of semiconductor thin films. (A strong electric field is applied even at low voltage)
- Insulation breakdown voltage is determined by measuring current flow while gradually increasing the applied voltage.

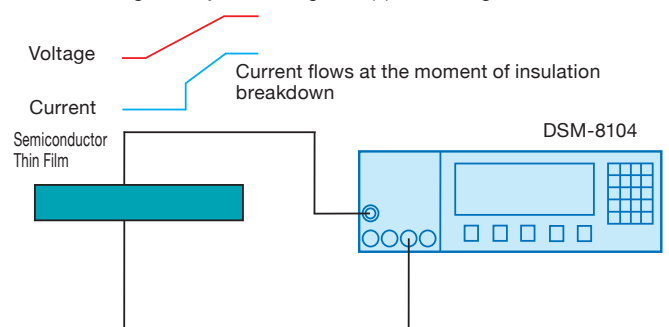

### Displaying a Histogram of Selected Results

- Measured values can be categorized and displayed in a bar graph indicating the number of occurrences of each value. The display scale is adjusted automatically so the maximum count always appears at the full display width. Category threshold values can be set as needed.

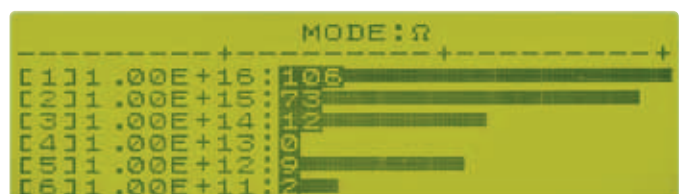

# Useful Information

## IGuards for Insulation Meters

Because an insulation meter measures very high resistances, stray currents passing through the insulators of the insulation meter itself can cause measurement aberrations, so guards are placed to prevent such aberrations.

As a means of defense or protection, these guards guide the leakage current away from objects that are not intended to be included in the measurement, such as the measurement leads and supporting insulators, to places where they will not affect measurements. The theory is shown below.

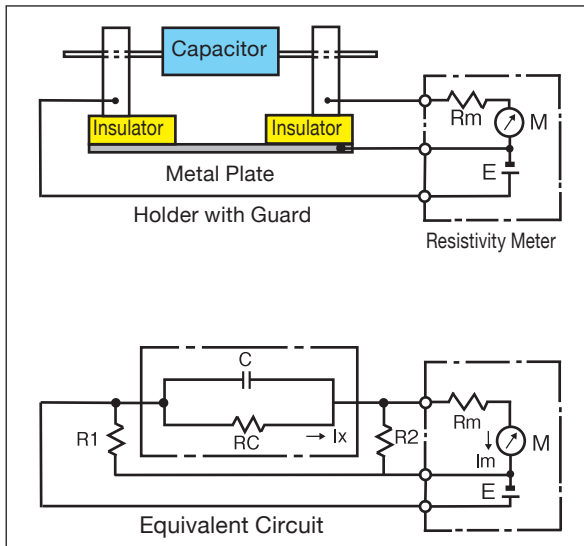

Guard Theory

$$\frac{I_m}{I_x} = \frac{R_2}{R_m + R_2}$$

$$\text{Aberration } \varepsilon = \frac{R_c'}{R_c} - 1 = \frac{I_x}{I_m} - 1 = \frac{R_m}{R_2}$$

However,  $R_c'$  is the resistance determined by  $I_m$ . To minimize the aberration,  $R_2 \gg R_m$ .

## Dielectric Absorption Phenomena

When a specific voltage is applied to an insulator to measure insulation resistance, a relatively large current flows initially, which current gradually decreases until it settles at a certain value.

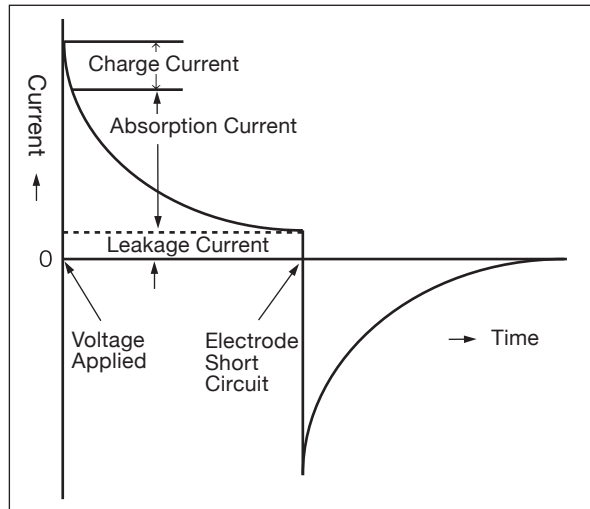

Absorption Current Characteristic Curve

As the curve indicates, the current flowing through an insulator is the sum of the charge current, absorption current and leakage current. So when measuring insulation resistance, the resistance value depends on the measurement duration. A common method for handling this is to read the resistance value one minute after voltage is applied, which is called the 'one-minute value' method. The polarization index can also be obtained as the ratio of the one-minute value to the ten-minute value.

## Resistivity

Resistivity (specific resistance) is measured to determine the quality of an insulating material.

Resistivity can be classified as volume resistivity or surface resistivity, respectively indicated by the resistance between two sides relative to that of a 1 cm<sup>3</sup> cube, or by the resistance relative to that of a 1 cm<sup>2</sup> surface. HIOKI's super megohmmeter series utilizes the SME-8310 and SME-8311 flat sample test fixtures to measure these two types of resistivity, respectively.

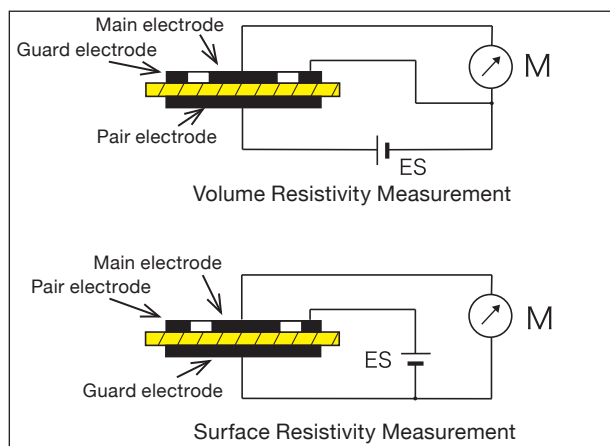

Flat Sample Measurement

Note: Company names and Product names appearing in this catalog are trademarks or registered trademarks of various companies.

**HIOKI**

HIOKI E. E. CORPORATION

**HEADQUARTERS:**

81 Koizumi, Ueda, Nagano, 386-1192, Japan  
TEL +81-268-28-0562 FAX +81-268-28-0568  
http://www.hioki.com / E-mail: os-com@hioki.co.jp

**HIOKI USA CORPORATION:**

TEL +1-609-409-9109 FAX +1-609-409-9108  
http://www.hiokiusa.com / E-mail: hioki@hiokiusa.com

**HIOKI (Shanghai) SALES & TRADING CO., LTD.:**  
TEL +86-21-63910090 FAX +86-21-63910360  
http://www.hioki.cn / E-mail: info@hioki.com.cn

**HIOKI INDIA PRIVATE LIMITED:**

TEL +91-124-6590210 FAX +91-124-6460113  
E-mail: hioki@hioki.in

**HIOKI SINGAPORE PTE. LTD.:**

TEL +65-6634-7677 FAX +65-6634-7477  
E-mail: info-sg@hioki.com.sg

**HIOKI KOREA CO., LTD.:**

TEL +82-42-936-1281 FAX +82-42-936-1284  
E-mail: info-kr@hioki.co.jp

DISTRIBUTED BY